

## INNOVATIVE, ECOLOGIC AND EFFICIENT TECHNOLOGIES FOR JOINING METALLIC AND POLYMERIC MATERIALS USED IN AUTOMOTIVE INDUSTRY BY FRICTION STIR WELDING (INOVA-FSW)

### Goal of the project

The project is focused on studying the possibilities of using Friction Stir Welding (FSW) for joining dissimilar material (metallic and polymeric) for automotive industry. Solid state welding process, like FSW, avoid the precipitation of secondary phases in the welded joint, resulting a high quality welded joint, even between materials impossible/difficult to weld with fusion welding processes. The main goal of the project is to obtain welding technologies for joining Al-Cu, Al-Steel, as well as different polymeric materials.

### Short description of the project

The project studies the possibility to join, by FSW, Al-Cu, Al-steel and different types of polymeric materials.

### Project implemented by

The partners in this project are: University Politehnica Timisoara (UPT), National R&D Institute for Welding and Material Testing – ISIM, Timisoara, University of Pitesti and Renault Technologie Roumanie (part of the Renault Group). The last partner will also implement the results of the project.

### Implementation period

14.07.2014 – 30.09.2017

### Main activities

The main activities of the project:

- defining the materials for the welding tools, technological parameters, testing procedures and quality specifications;
- experimental studies for joining Al (and aluminum alloys) with Cu (and copper alloys) and different polymeric materials;
- experimental studies for joining Al (and aluminum alloys) with steel;
- numerical modeling of FSW welding of dissimilar materials;
- testing of welded joints, optimization of the welding procedures (building a data base with results);
- dissemination of the results.

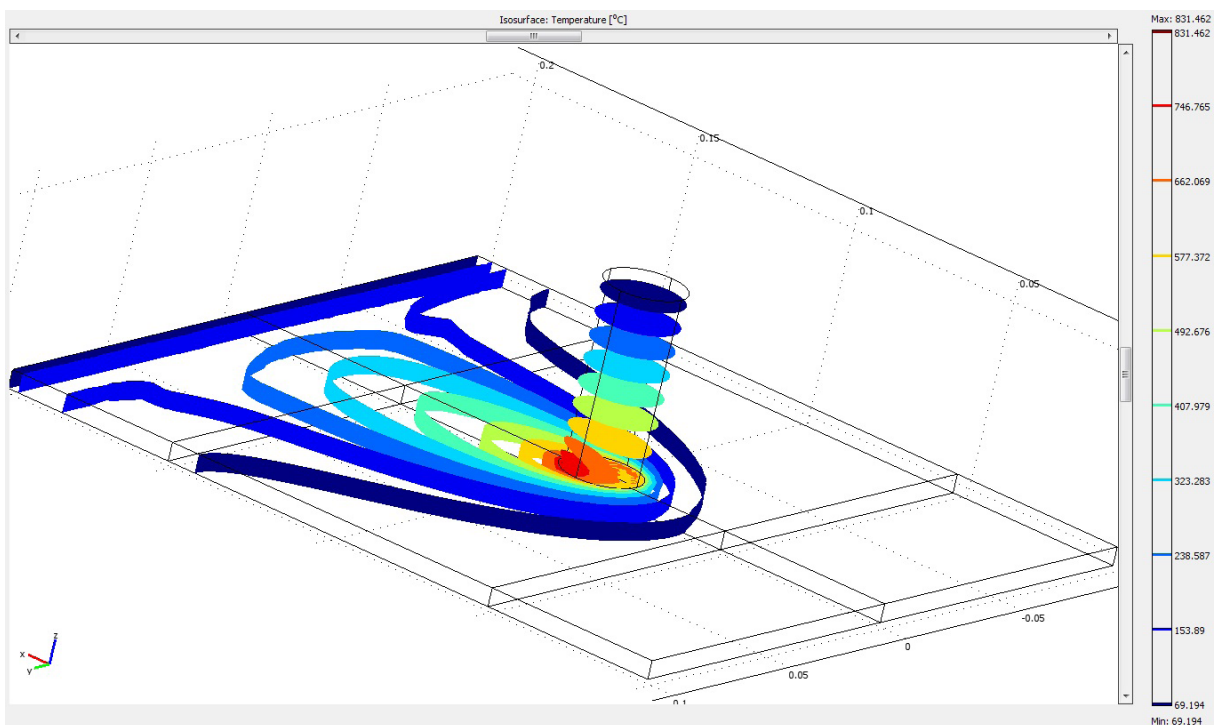

## Results

The project results are materialized in more than 10 FSW technologies (tested and certified), for joining aluminum alloys with copper alloys, aluminum alloys with steel and also different polymeric materials. Also, there were 6 scientific papers that were published, based on the results of this project.

## Applicability and transferability of the results

The result of the project will be transferred and applied mainly at the partner Renault Technologie Roumanie (part of the Renault Group), but they are available to all industrial entities working mainly in automotive industry.

## Financed through/by

UEFISCDI in grant PN-II-PT-PCCA-2013-4-1858 (Inova-FSW, contract 219/2014).

## Research Centre

ICER – Institutul de Cercetari pentru Energii Regenerabile

## Research team

University Politehnica Timisoara (UPT);  
National R&D Institute for Welding and Material Testing  
– ISIM, Timisoara;  
University of Pitesti  
Renault Technologie Roumanie (part of the Renault Group).

## Contact information

conf. Bogdan RADU, PhD  
Department Materials Engineering and Fabrication,  
b-dul Mihai Viteazul nr. 1, 300222, Timisoara  
Phone: (+40) 256 403647  
Mobile: +40746190268  
E-mail: bogdan.radu@upt.ro  
Web: <http://www.inovafsw.upt.ro/>